



Fast Speed switching Diode

MMSD914

FEATURES

- SOD-123 surface mount package.
- High breakdown voltage.
- Fast speed switching time.

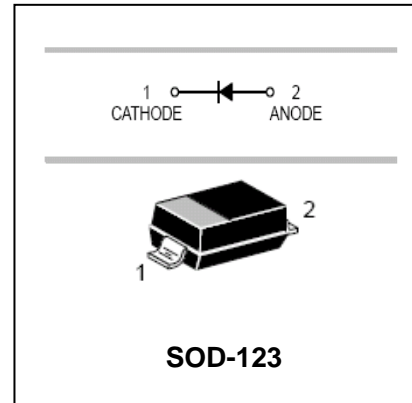

APPLICATIONS

- Surface mount fast switching diode.

ORDERING INFORMATION

Type No.	Marking	Package Code
MMSD914	5DI	SOD-123

MAXIMUM RATING @ Ta=25°C unless otherwise specified

Characteristic	Symbol	Value	Unit
Maximum repetitive reverse voltage	V_{RRM}	100	V
Continuous reverse Voltage	V_R	100	V
Average Rectified Forward Current	$I_{F(AV)}$	200	mA
Peak Forward Surge Current	I_{FSM}	1.0 2.0	A
	@t=1s @t=1ms		
Power Dissipation	P_d	400	mW
Thermal Resistance, Junction to Ambient	$R_{\theta JA}$	312	°C/W
Storage Temperature Range	T_{STG}	-55 to +150	°C
Operating Junction Temperature	T_j	150	°C



Fast Speed switching Diode

MMSD914

ELECTRICAL CHARACTERISTICS @ Ta=25°C unless otherwise specified

Characteristic	Symbol	Min	Max	Unit	Test Condition
Reverse Breakdown Voltage	$V_{(BR)R}$	100 75		V	$I_R=100\mu A$ $I_R=5.0\mu A$
Forward Voltage	V_F		1.0	V	$I_F=10mA$
Reverse Current	I_R		25 5.0	nA μA	$V_R=20V$ $V_R=75V$
Diode Capacitance	C_D	-	4.0	pF	$V_R=0, f=1.0MHz$
Reverse Recovery Time	t_{rr}	-	4.0	ns	$I_F=10mA, V_R=6.0V,$ $I_{RR}=1.0mA, R_L=100\Omega$

TYPICAL CHARACTERISTICS @ Ta=25°C unless otherwise specified

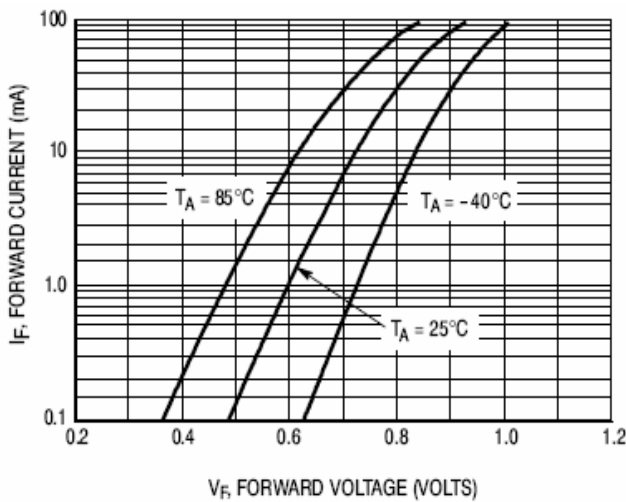

Figure 1. Forward Voltage

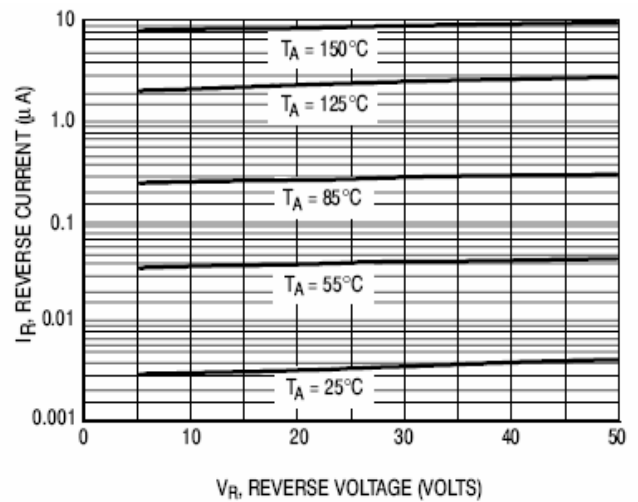

Figure 2. Leakage Current

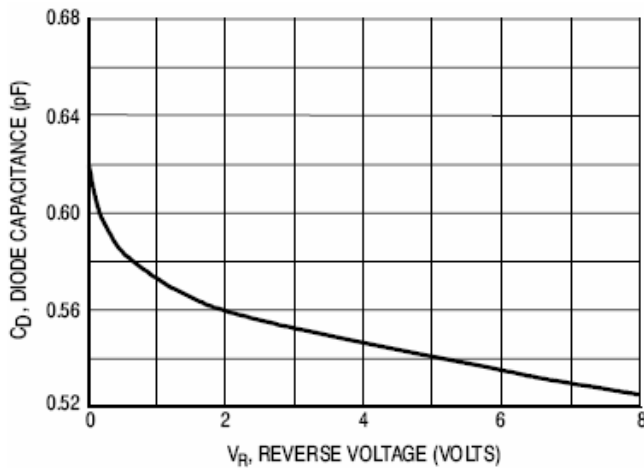

Figure 3. Capacitance



Fast Speed switching Diode

MMSD914

PACKAGE OUTLINE

Plastic surface mounted package

SOD-123

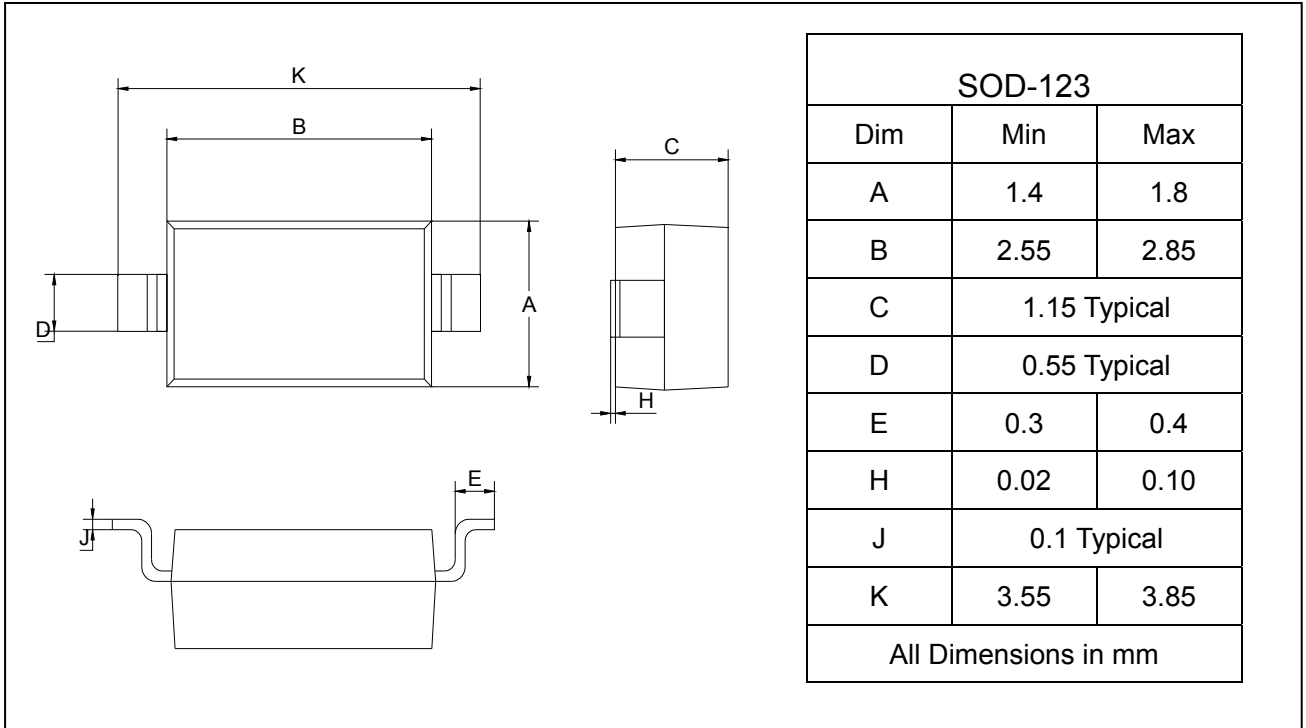

SOLDERING FOOTPRINT

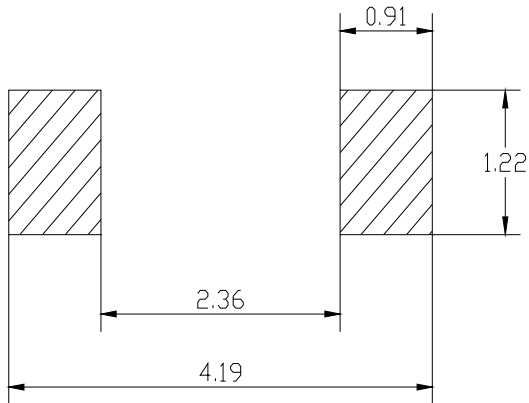

Unit: mm

PACKAGE INFORMATION

Device	Package	Shipping
MMSD914	SOD-123	3000/Tape&Reel